

## Additional Products

Advance Engineering Corporation owns its own pipe nipple manufacturing company, Perfect Pipe & Supply Corporation. We offer high quality and competitive pipe nipple and swage nipple products. We specialize in exceptional quality threaded pipe!



- Steel, Stainless, Brass and Aluminum materials
- Available in standard and extra heavy steel
- Threading 1/8" thru 4" pipe and up to 21' lengths
- Close tolerance ANPT (CTT) on Pipe Nipples
- Available with Standard, Zinc, Epoxy and Wet Applied Enamel Finishes



**Bollards/Meter Guards** - Protect your meter set in the field with fabricated bollard/meter guards. We provide standard sizes or customized to your needs.

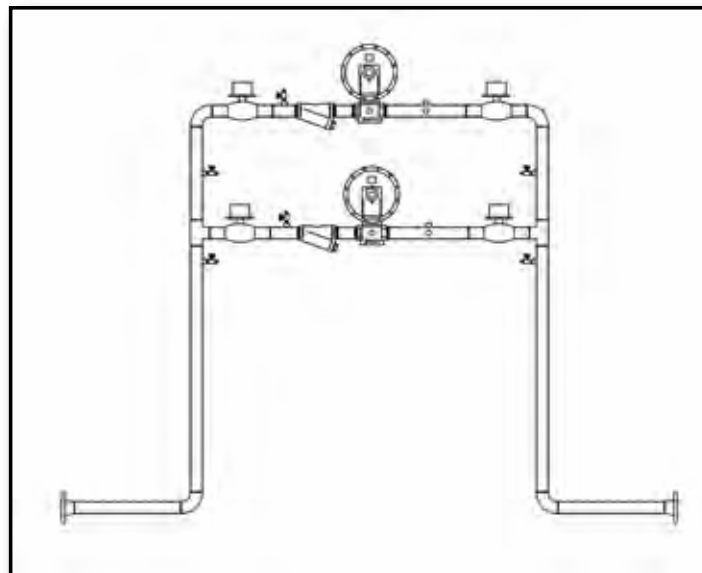
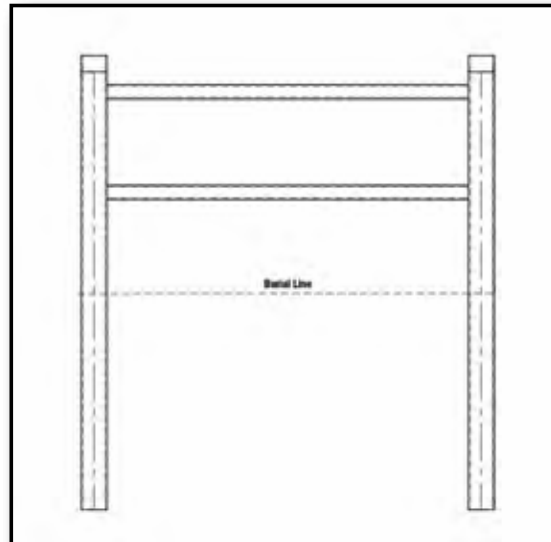

**Farm Tap Assemblies- Welded or Assembled**

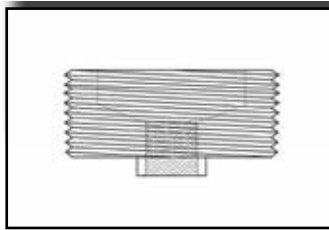

**Test Adapters**

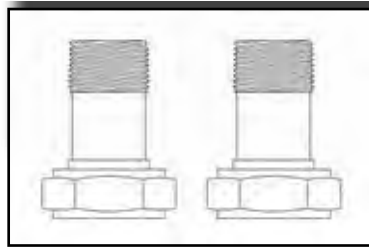

**Meter Nuts & Swivels,  
Blind Swivels**

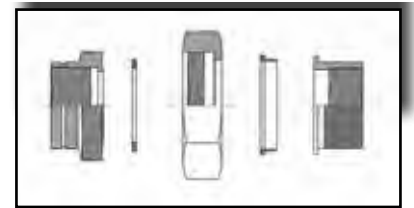

**ANPT Insulated Unions 3/4" - 2"**

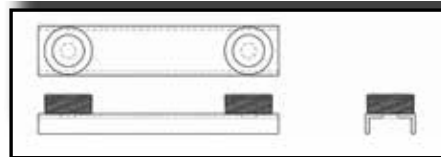

**Meter Templates**

**Meter Gaskets and Swivel**

Part No.	Part	Gasket			Swivels		
		O.D. (in)	I.D. (in)	Width (in)	Pilot Dia.	Flange Dia.	Pilot Length
PF1000-20	20LT	1.614	1.24	0.0945	1/312	1.687	0.188
PF1010-1	10LT	1.273	.0965	0.0945	1	1.312	0.156
PF1020-1	30LT	1.938	1.424	0.128	1.5	1.906	0.25
PF1100-1	45LT	2.122	1.701	0.0945	1.703	2.125	0.25
PF1101-1	#3 & #4	2.102	1.508	0.0945	1.5	2.218	0.188
PF1200-1	1A/OEMCO	1.376	0.933	0.0945	1	1.468	0.188
PF5903-1	#5	3.189	2.311	0.0945	2.312	3.25	0.25

Rubber P.F. Gasket, Hardness Shore 'A' 50 5, Tensile Strength (Kg CM-2) 122, Ultimate Elongation Break (%) 550

## Additional Services

- Stocking Options
- CAD Drawings
- Build To Order
- QC Procedures & Processes
- Field Training
- Forecasting
- Design & Project Management Development
- Key Project Manager Contact Available 24/7
- B117 Testing Capabilities
- Shared Cost Partnership Programs
- Excellent Quality & Service
- Competitive Pricing